

RECOMMENDED PCB LAYOUT
(GENERAL TOLERANCE ±0.05)

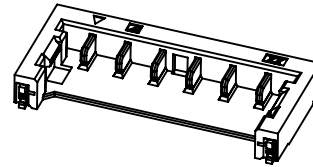

NOTES:

- MATERIAL:
 - HOUSING: THERMOPLASTIC, HIGH TEMP., UL94V-0; COLOR:BLACK.
 - CONTACT: COPPER ALLOY
 - FITTING NAIL: COPPER ALLOY
- FINISH:
 - CONTACT:
 - 50u" MIN NICKEL PLATING OVERALL
 - A:3u" MIN GOLD ON CONTACT AREA
 - GOLD FLASH ON SOLDER AREA
 - FITTING NAIL:
 - 50~100u" NICKEL PLATING OVERALL
 - 80~120u" MATT TIN ON PLATING AREA
- SPEC. PLS. REFER TO PS-51263-XXXX-XXX
- PACKAGE PLS. REFER TO 51263-XXXX-XX-TRP
- PART NUMBER

51263-XXX X X-XXX		001	LCP&Black
CKTS		003	LCP&Nature
PACKING		PLATING	
0: TAPE&REEL		A: 3u" GOLD ON CONTACT(LEAD FREE)	

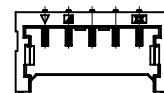
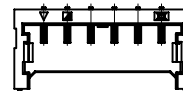

CKT	DIM A	DIM B	DIM C	DIM D
2	1.20	2.65	4.20	3.65
4	3.60	5.05	6.60	6.05
6	6.00	7.45	9.00	8.45
8	8.40	9.85	11.40	10.85

QUALITY SYMBOLS MAJOR Ⓢ CRITICAL Ⓢ	DRAWN BY ZHANG HAO	DATE 18/04/04	ACES ELECTRONICS	
	CHECKED BY BRAVE	DATE 18/04/04		
GENERAL TOLERANCES (UNLESS SPECIFIED) X ±0.5 .X ±0.25 .XX ±0.15 .XXX ±0.1 ANGLES ±2°	APPROVED BY BRAVE	DATE 18/04/04	TITLE 1.2mm WTB WAFER CONN. SMT S/R R/A TYPE	
	UNITS mm		SIZE A4	DWG NO. 51263-XXXX-XXX
	SCALE 1:1	SHEET NO. 1 OF 2	REV D	PART NO. SEE NOTES

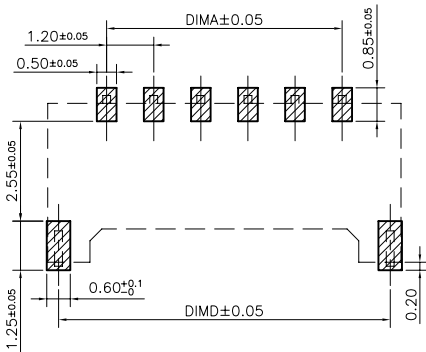
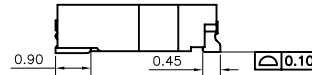
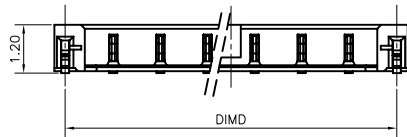
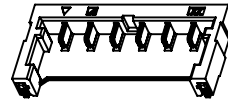
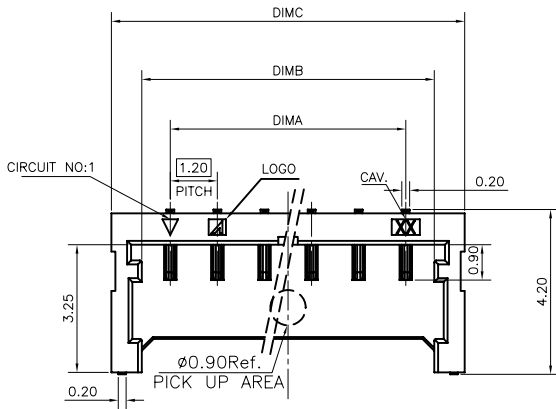

RECOMMENDED PCB LAYOUT
(GENERAL TOLERANCE ± 0.05)

NOTES:

1. MATERIAL:
 - 1.1 HOUSING: THERMOPLASTIC, HIGH TEMP., UL94V-0; COLOR:BLACK.
 - 1.2 CONTACT: COPPER ALLOY
 - 1.3 FITTING NAIL: COPPER ALLOY
2. FINISH:
 - 2.1 CONTACT:
 - 50u" MIN NICKEL PLATING OVERALL
 - A:3u" MIN GOLD ON CONTACT AREA
 - GOLD FLASH ON SOLDER AREA
 - 2.2 FITTING NAIL:
 - 50~100u" NICKEL PLATING OVERALL
 - 80~120u" MATT TIN ON PLATING AREA
3. SPEC. PLS. REFER TO PS-51263-XXXXX-XXX
4. PACKAGE PLS. REFER TO 51263-XXXXX-XX-TRP
5. PART NUMBER

51263-XXX X X-XXX

CKTS ———— 002:無LOCK

PACKING ———— PLATING

0: TAPE&REEL

A: 3u" GOLD ON CONTACT(LEAD FREE)

1: TUBE

CKT	DIM A	DIM B	DIM C	DIM D
6	6.00	7.45	9.00	8.45

QUALITY SYMBOLS MAJOR CRITICAL	DRAWN BY ZHANG HAO	DATE 18/04/04		
	CHECKED BY BRAVE	DATE 18/04/04		
GENERAL TOLERANCES (UNLESS SPECIFIED) X. ± 0.5 .X ± 0.25 .XX ± 0.15 .XXX ± 0.1 ANGLES $\pm 2^\circ$	APPROVED BY BRAVE	DATE 18/04/04	TITLE 1.2mm WTB WAFER CONN. SMT S/R R/A TYPE	
	UNITS mm		SIZE A4	DWG NO. 51263-XXXXX-XXX
	SCALE 1:1	SHEET NO. 2 OF 2	REV D	PART NO. SEE NOTES